

Maximum Rating Tables

Size 821 • GR, NH, EL Series



Style B

Style H



Size 821

Ratio	nput RPM	Output RPM	nput HP	Output HP	Output Torque (lb in)	Left Hand Catalog No	Right Hand Catalog No	Double Extension Catalog No	Hollow Output Catalog No *
5	2500	500	4 305	4 043	510	8210001	8210013	8210025	8210501.XX
	1750	350	3 653	3 410	614				
	1170	234	2 873	2 657	716				
7.5	100	20	0 433	0 310	977	8210002	8210014	8210026	8210502.XX
	2500	333	3 300	3 051	577				
	1750	233	2 793	2 562	692				
10	1170	156	2 194	1 989	804	8210003	8210015	8210027	8210503.XX
	100	13	0 341	0 230	1089				
	2500	250	2 973	2 722	686				
15	1750	175	2 464	2 235	805	8210004	8210016	8210028	8210504.XX
	1170	117	1 905	1 702	917				
	100	10	0 300	0 189	1192				
20	2500	166	2 284	2 035	769	8210005	8210017	8210029	8210505.XX
	1750	116	1 887	1 661	897				
	1170	78	1 459	1 259	1017				
25	100	6.7	0 245	0 138	1309	8210006	8210018	8210030	8210506.XX
	2500	125	1 914	1 642	828				
	1750	87	1 584	1 338	964				
30	1170	58	1 229	1 012	1090	8210007	8210019	8210031	8210507.XX
	100	5.0	0 226	0 111	1397				
	2500	100	1 623	1 359	857				
40	1750	70	1 333	1 094	985	8210008	8210020	8210032	8210508.XX
	1170	46	1 030	0 820	1104				
	100	4.0	0 200	0 088	1386				
50	2500	83	1 359	1 102	833	8210009	8210021	8210033	8210509.XX
	1750	58	1 129	0 896	968				
	1170	39	0 882	0 677	1095				
60	100	3.3	0 181	0 074	1399	8210010	8210022	8210034	8210510.XX
	2500	62	1 096	0 829	836				
	1750	43	0 916	0 674	971				
80	1170	29	0 722	0 509	1097	8210011	8210023	8210035	8210511.XX
	100	2.5	0 167	0 056	1401				
	2500	50	0 925	0 670	845				
100	1750	35	0 769	0 539	970	8210012	8210024	8210036	8210512.XX
	1170	23	0 606	0 403	1086				
	100	2.0	0 149	0 043	1359				
100	2500	41	0 799	0 535	809	8210011	8210023	8210035	8210511.XX
	1750	29	0 674	0 435	940				
	1170	19	0 539	0 328	1061				
100	100	1.7	0 145	0 036	1354	8210012	8210024	8210036	8210512.XX
	2500	31	0 357	0 236	476				
	1750	21	0 304	0 190	547				
100	1170	14	0 241	0 141	609	8210012	8210024	8210036	8210512.XX
	100	1.3	0 034	0 015	743				
	2500	25	0 251	0 150	379				
100	1750	17	0 217	0 122	439	8210012	8210024	8210036	8210512.XX
	1170	11	0 175	0 091	491				
	100	1.0	0 026	0 010	605				

How To Build a Part Number For Size GRG821, GRL821, NH821, EL821

1. Select partial catalog number from the selection table
2. Replace leading “_” with series code (GRG, GRL, NH, EL) (see next page for codes)
3. For hollow output, replace “XX” suffix with bore code

Example:

Direct replacement to LEESON IRONMAN, style B, 5:1 ratio, left hand output
 GRL-B821-5-L
 GRL8210001

GRG = **GROVE GEAR**

- Direct replacement to Grove Gear Flexaline
- Mounting footprint 3 00” x 4 75”
- See pages 52 73 for dimensions

GRL = **IRONMAN** interchange

- Direct replacement to LEESON IRONMAN & major brands
- Mounting footprint 2 88” x 5 00”
- See pages 52 73 for dimensions





Maximum Rating Tables

Size 821 • GR, NH, EL Series

	Style BM			Style HM	Style BMQ			Style HMQ	
NEMA C nput Flange ▲	Left Hand Catalog No	Right Hand Catalog No	Double Extension Catalog No	Hollow Output Catalog No *	Left Hand Catalog No	Right Hand Catalog No	Double Extension Catalog No	Hollow Output Catalog No *	Ratio
56C 143 5TC	8210037 8210073	8210049 8210085	8210061 8210097	8210513.XX 8210525.XX	8210109 8210145	8210121 8210157	8210133 8210169	8210537.XX 8210549.XX	5
56C 143 5TC	8210038 8210074	8210050 8210086	8210062 8210098	8210514.XX 8210526.XX	8210110 8210146	8210122 8210158	8210134 8210170	8210538.XX 8210550.XX	7.5
56C 143 5TC	8210039 8210075	8210051 8210087	8210063 8210099	8210515.XX 8210527.XX	8210111 8210147	8210123 8210159	8210135 8210171	8210539.XX 8210551.XX	10
56C 143 5TC	8210040 8210076	8210052 8210088	8210064 8210100	8210516.XX 8210528.XX	8210112 8210148	8210124 8210160	8210136 8210172	8210540.XX 8210552.XX	15
56C 143 5TC	8210041 8210077	8210053 8210089	8210065 8210101	8210517.XX 8210529.XX	8210113 8210149	8210125 8210161	8210137 8210173	8210541.XX 8210553.XX	20
56C 143 5TC	8210042 8210078	8210054 8210090	8210066 8210102	8210518.XX 8210530.XX	8210114 8210150	8210126 8210162	8210138 8210174	8210542.XX 8210554.XX	25
56C 143 5TC	8210043 8210079	8210055 8210091	8210067 8210103	8210519.XX 8210531.XX	8210115 8210151	8210127 8210163	8210139 8210175	8210543.XX 8210555.XX	30
56C 143 5TC	8210044 8210080	8210056 8210092	8210068 8210104	8210520.XX 8210532.XX	8210116 8210152	8210128 8210164	8210140 8210176	8210544.XX 8210556.XX	40
56C 143 5TC	8210045 8210081	8210057 8210093	8210069 8210105	8210521.XX 8210533.XX	8210117 8210153	8210129 8210165	8210141 8210177	8210545.XX 8210557.XX	50
48CZ 56C 143 5TC	8210190 8210046 8210082	8210202 8210058 8210094	8210214 8210070 8210106	8210570.XX 8210522.XX 8210534.XX	8210226 8210118 8210154	8210238 8210130 8210166	8210250 8210142 8210178	8210582.XX 8210546.XX 8210558.XX	60
48CZ 56C	8210191 8210047	8210203 8210059	8210215 8210071	8210571.XX 8210523.XX	8210227 8210119	8210239 8210131	8210251 8210143	8210583.XX 8210547.XX	80
48CZ 56C	8210192 8210048	8210204 8210060	8210216 8210072	8210572.XX 8210524.XX	8210228 8210120	8210240 8210132	8210252 8210144	8210584.XX 8210548.XX	100

For input/ output shaft overhung load and thrust load ratings, refer to pages 419-422.

▲ Consult Factory for other motor flanges available.

* Catalog numbers are for hollow output shaft reducers.

When ordering, substitute the XX suffix with the required output bore code.

Available bore codes

Fraction Size	1"	1-1/8"	1-3/16"	1-1/4"	1-7/16"	1-1/2"
Decimal Size	1.000	1.125	1.188	1.250	1.438	1.500
Output Bore Code	16	18	19	20	23	24

Single Reduction
Worm Gear Reducers

Double Reduction
Worm - Worm Gear Reducers

Double Reduction
Helical - Worm Gear Reducers

WASHGUARD® Reducers
and GEAR+MOTOR™

Ratio Multipliers

Accessories and
Additional Capabilities



GR Series Dimensions

Styles: BMQ, BM, B

**CAST IRON
GR SERIES**

Single Reduction
Worm Gear Reducers

Double Reduction
Worm - Worm Gear Reducers

Double Reduction
Helical - Worm Gear Reducers

WASHGUARD® Reducers
and GEAR+MOTOR™

Ratio Multipliers

Accessories and
Additional Capabilities

Style BMQ

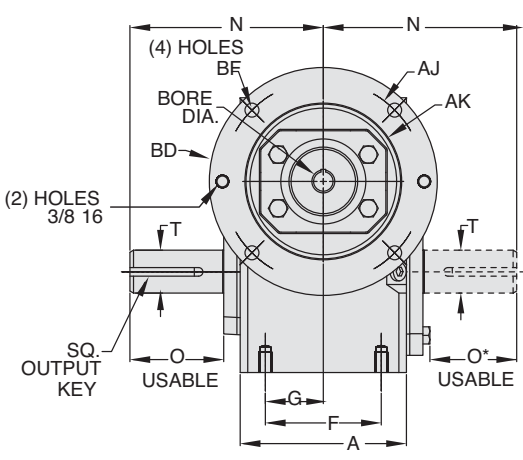
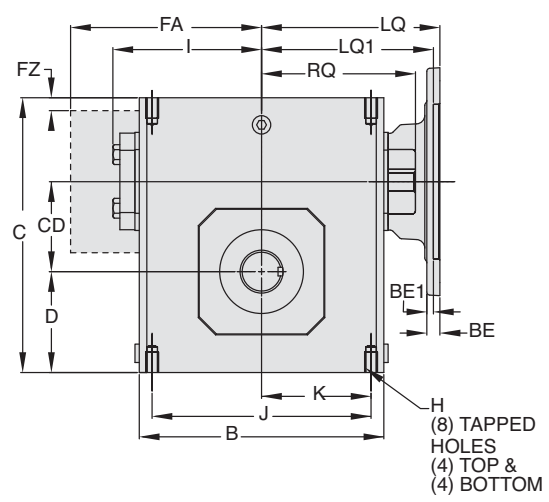

ASSEMBLIES

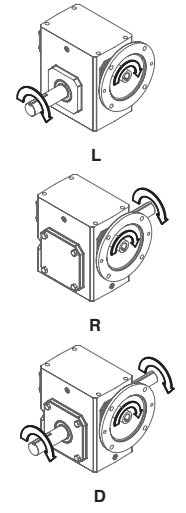

Style BM

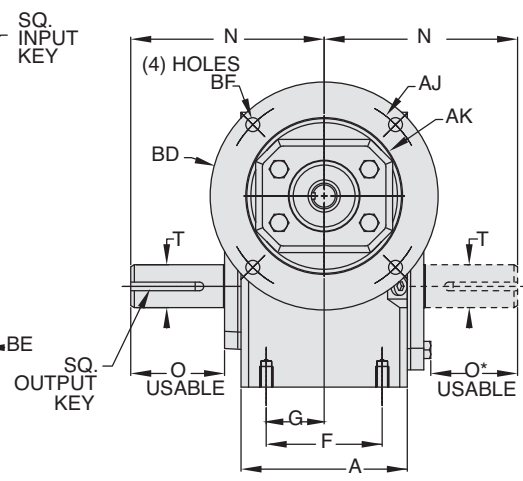
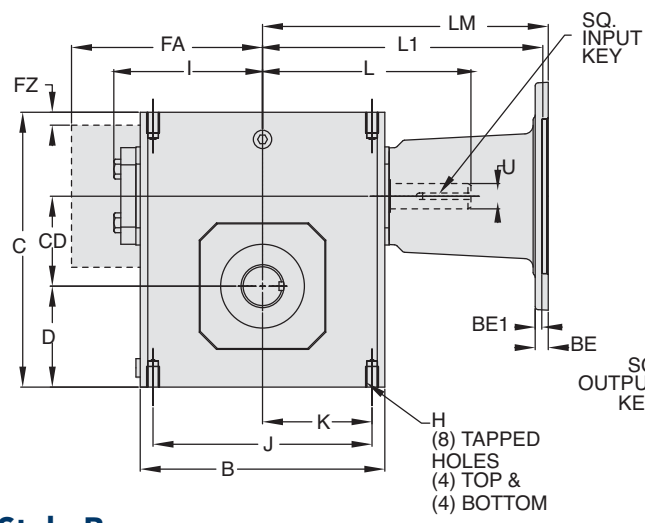

ASSEMBLIES

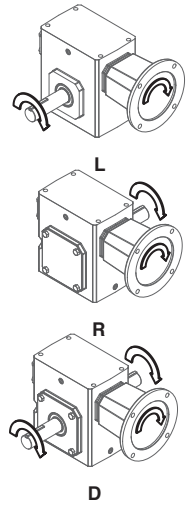

Style B

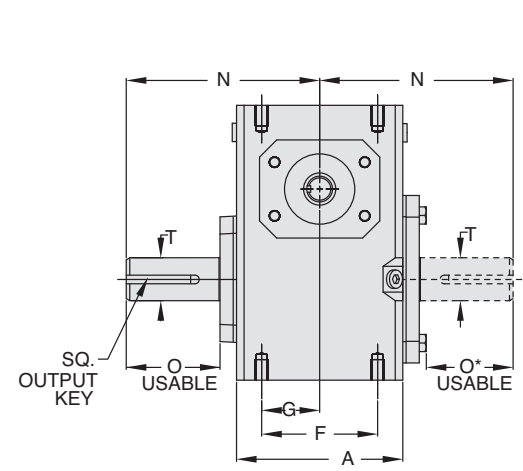
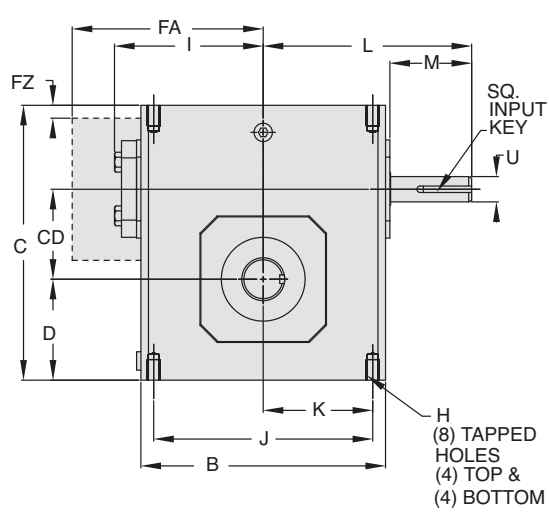

ASSEMBLIES

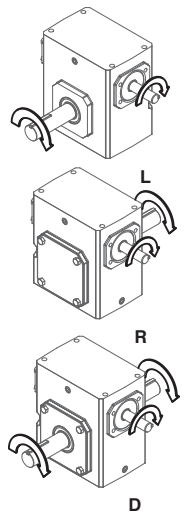

REVERSE ALL ARROWS
FOR OPPOSITE INPUT SHAFT
ROTATION. CONTACT FACTORY
FOR OTHER MOUNTINGS OR
ASSEMBLY POSITIONS.



STYLE BMQ, BM, B DIMENSIONS (Inches)

Size	A	B	C	D	CD	F	FA ▼	FZ ▼	G	H		I	J	K	L	M	N	O	O*	T +0.000 -0.0015	U +0.000 -0.0015	Input Key*	Output Key
										Tap Size	Depth												
GR813	2.82	3.80	4.66	1.72	1.33	2.00	N/A	N/A	1.00	5/16-18 UNC	.50	2.61	3.25	1.63	3.82	1.76	4.00	2.16	1.94	.625	.500	1/8 X 1.00	3/16 X 1.50
GR815	3.44	4.88	5.38	1.91	1.54	2.75	N/A	N/A	1.38	5/16-18 UNC	.63	3.14	4.19	2.09	4.35	1.76	4.31	2.11	1.90	.750	.625	3/16 X 1.38	3/16 X 1.50
GR818	3.56	5.06	5.75	2.06	1.75	2.75	N/A	N/A	1.38	5/16-18 UNC	.63	3.24	4.19	2.09	4.45	1.76	4.31	2.05	1.84	.875	.625	3/16 X 1.38	3/16 X 1.38
GR821	3.81	5.80	6.38	2.28	2.06	▲	N/A	N/A	1.44	5/16-18 UNC	.63	3.61	▲	2.50	4.82	1.76	4.68	2.29	2.08	1.000	.625	3/16 X 1.38	1/4 X 1.44
GR824	4.06	6.12	6.94	2.50	2.38	2.88	N/A	N/A	1.44	3/8-16 UNC	.69	3.77	5.00	2.50	5.51	2.38	5.14	2.66	2.44	1.125	.750	3/16 X 1.63	1/4 X 1.75
GR826	4.84	7.12	8.00	2.94	2.63	3.38	N/A	N/A	1.69	3/8-16 UNC	.69	4.34	6.38	3.19	6.07	2.38	5.63	2.73	2.52	▲	.750	3/16 X 1.63	1/4 X 1.75
GR830	5.25	8.12	8.88	3.25	3.00	4.00	N/A	N/A	2.00	7/16-14 UNC	.88	4.84	7.00	3.50	6.57	2.38	6.75	3.60	3.36	1.250	.875	3/16 X 1.63	1/4 X 1.75
GR832	5.75	8.50	9.38	3.50	3.25	4.00	N/A	N/A	2.00	7/16-14 UNC	.88	5.02	7.50	3.75	6.76	2.38	7.06	3.66	3.42	▲	.875	3/16 X 1.63	▲
GR842	6.13	10.25	11.38	4.44	4.25	5.00	N/A	N/A	2.50	5/8-11 UNC	1.00	6.10	8.50	4.25	9.57	3.47	8.12	4.50	4.21	1.875	1.250	1/4 X 2.50	1/2 X 3.06
GR852	7.19	13.00	14.00	5.12	5.25	5.81	N/A	N/A	2.91	5/8-11 UNC	1.25	7.50	11.00	5.50	10.88	3.38	9.06	4.78	4.53	2.000	1.250	1/4 X 3.00	1/2 X 3.50
GR860	8.13	14.25	16.50	6.50	6.00	6.38	11.13	0.33	3.19	5/8-11 UNC	1.00	N/A	12.75	6.38	11.78	3.41	10.00	4.65	4.65	2.500	1.500	3/8 X 3.00	5/8 X 4.00
GR870	7.63	14.88	18.91	7.59	7.00	5.50	11.37	0.35	2.75	1-8 UNC	1.56	N/A	12.50	6.25	11.50	2.97	11.76	5.65	5.65	2.750	1.625	3/8 x 2.87**	5/8 x 4.00**
GR880	8.63	17.00	20.96	8.86	8.00	6.50	12.52	0.57	3.25	1-8 UNC	1.66	N/A	14.25	7.13	12.50	2.84	12.25	5.98	5.98	3.000	1.875	1/2 x 2.81**	3/4 x 4.50**
GR8100	9.53	20.88	25.47	10.36	10.00	6.88	14.69	0.51	3.44	1-1/4 -7 UNC	2.04	N/A	17.75	8.88	15.50	3.76	14.75	6.76	6.76	3.750	2.250	1/2 x 3.69**	7/8 x 5.00**

▲ See feature comparison chart.

FEATURE COMPARISON (821, 826, 832)

Size	Output Shaft Diameter Needed?	Mounting Footprint Needed?	Output Key Needed?	All Other Features	Grove Gear Flexaline Interchange	LEESON IRONMAN Interchange	Replace With Series Code Below:
821	Identical	(F)3.00" x (J)4.75"	Identical	Identical	✓	✓	GRG
		(F)2.88" x (J)5.00"					GRL
826	1.250"	Identical	Identical	Identical	✓	✓	GRG
	1.125"						GRL
832	1.500"	Identical	3/8 x 2.63	Identical	✓	✓	GRG
	1.375"		5/16 x 2.63				GRL

Motor Mounting Dimensions

NEMA DIMENSIONS (Inches)

Size	LM		180TC/210TC	L1	250TC	LQ		180TC	LQ1	210TC	250TC	RQ			
	48CZ	56C/140TC				48CZ/56C/140TC	56C/140TC					48CZ/56C/140TC	180TC	210TC	250TC
GR813	5.63	6.07	N/A	N/A	3.46	N/A	N/A	N/A	3.09	N/A	N/A	N/A	N/A	N/A	N/A
GR815	6.16	6.60	N/A	N/A	3.99	N/A	N/A	N/A	3.62	N/A	N/A	N/A	N/A	N/A	N/A
GR818	6.26	6.70	N/A	N/A	4.09	N/A	N/A	N/A	3.59	N/A	N/A	N/A	N/A	N/A	N/A
GR821*	6.63	7.07	N/A	N/A	4.46	N/A	N/A	N/A	4.06	N/A	N/A	N/A	N/A	N/A	N/A
GR824	N/A	7.76	8.76	N/A	4.63	5.06	N/A	N/A	4.09	4.56	N/A	N/A	N/A	N/A	N/A
GR826*	N/A	8.32	9.32	N/A	5.19	5.62	N/A	N/A	4.82	5.13	N/A	N/A	N/A	N/A	N/A
GR830	N/A	8.82	9.82	N/A	5.95	6.15	6.56	N/A	5.32	5.63	6.06	N/A	N/A	N/A	N/A
GR832*	N/A	9.01	10.01	N/A	6.14	6.34	6.75	N/A	5.51	5.81	6.25	N/A	N/A	N/A	N/A
GR842	N/A	11.81	12.90	13.46	6.45	7.21	7.21	7.77	6.04	6.68	6.68	7.24	N/A	N/A	N/A
GR852	N/A	13.21	14.30	14.86	7.85	8.61	8.61	9.17	7.35	7.98	7.98	8.54	N/A	N/A	N/A
GR860	N/A	N/A	15.88	16.50	10.45	9.33	9.33	9.94	10.01	8.69	8.69	8.69	N/A	N/A	N/A
GR870	N/A	N/A	15.50	15.50	N/A	N/A	N/A	N/A	N/A	N/A	N/A	N/A	N/A	N/A	N/A
GR880	N/A	N/A	16.58	16.58	N/A	N/A	N/A	N/A	N/A	N/A	N/A	N/A	N/A	N/A	N/A

NEMA DIMENSIONS (Inches)

Frame	Ajb	AK	BD	BE	BE1	Bore Dia.	Keyway	BFB
48CZ	3.75	3.00	4.36	0.38	N/A	.500	1/8 X 1/16	0.28
56C	5.88	4.50	6.50	0.38	N/A	.625	3/16 X 3/32	0.41
140TC	5.88	4.50	6.50	0.38	N/A	.875	3/16 X 3/32	0.41
180TC	7.25	8.50	9.00	N/A	0.50	1.125	1/4 X 1/8	0.53
210TC	7.25	8.50	9.00	N/A	0.50	1.375	5/16 X 5/32	0.53
250TC	7.25	8.50	9.00	N/A	0.50	1.625	3/8 X 3/16	0.53

IEC B5 & B3/B5 METRIC DIMENSIONS (Inches)*

Size	LQ1					RQ						
	D63D	D71D	D80D	D90D	D100LD/D112MD	D132D	D63D	D71D	D80D	D90D	D100LD/D112MD	D132D
GR813	2.62	2.65	2.89	N/A	N/A	N/A	2.45	2.47	2.71	N/A	N/A	N/A
GR815	3.15	3.18	3.42	N/A	N/A	N/A	2.98	3.00	3.24	N/A	N/A	N/A
GR818	3.25	3.28	3.52	N/A	N/A	N/A	2.95	2.97	3.21	N/A	N/A	N/A
GR821*	3.62	3.65	3.89	N/A	N/A	N/A	3.43	3.44	3.68	N/A	N/A	N/A
GR824	N/A	3.72	4.34	N/A	N/A	N/A	3.46	3.71	N/A	N/A	N/A	N/A
GR826*	N/A	4.28	4.90	4.90	5.30	N/A	N/A	4.09	4.72	4.72	5.07	N/A
GR830	N/A	4.78	5.41	5.41	5.88	N/A	N/A	4.59	5.22	5.22	5.57	N/A
GR832*	N/A	4.97	5.59	5.59	6.07	N/A	N/A	4.78	5.41	5.41	5.76	N/A
GR842	N/A	N/A	N/A	6.38	6.39	7.17	N/A	N/A	N/A	6.16	6.14	6.93
GR852	N/A	N/A	N/A	7.78	7.78	8.57	N/A	N/A	N/A	7.46	7.45	8.24

IEC B5 & B3/B5 METRIC DIMENSIONS (MM)

Frame	AJ	AK	BD	BE	Bore Dia.	Keyway	BF TAP	OD
D63D	115	95	117	10	11	4 X 2	M8 X 1.25	131
D71D	130	110	132	11	14	5 X 2.5	M8 X 1.25	146
D80D	165	130	165	15	19	6 X 3	M10 X 1.50	184
D90D	165	130	165	15	24	8 X 3.5	M10 X 1.50	184
D100LD/D112MD	215	180	216	18	28	8 X 3.5	M12 X 1.75	237
D132D	265	230	267	18	38	10 X 4	M12 X 1.75	290

* Applies to double output shaft

** Key not provided with gear reducer. Keyway dimension shown.

◆ Keyway width by depth

⊙ Mounting holes rotated 45 degrees from positions shown on Size GR860, Style BM with frame sizes 180TC-250TC.

■ 48CZ not available

● 180TC not available

⊕ Metric IEC B5 input flange options are available only on quill input styles.

* Dimensions same for GRG and GRL Series

⊙ Style B and BM only.

▼ Sizes 860-8100 are supplied with a fan. Dimensions refer to fan guard location.

WARNING

For safety, purchaser or user should provide protective guards over shaft extensions and any couplings, sheaves and belts, sprockets and chains, etc., mounted thereon.

Single Reduction
Worm Gear Reducers

Double Reduction
Worm - Worm Gear Reducers

Double Reduction
Helical - Worm Gear Reducers

WASHGUARD® Reducers
and GEAR-HOTOR™

Ratio Multipliers

Accessories and
Additional Capabilities